

Experience in motion.



CUSTOM COMPONENTS FOR CARGO AND SERVICE TRUCKS
COMPONENTI CUSTOM PER CAMION DA TRASPORTO E SERVIZIO



VESTA RANGE FOR THE TRANSPORTATION INDUSTRY

IL RANGE VESTA PER IL SETTORE DEI TRASPORTI

PNEUMATIC CYLINDERS CILINDRI PNEUMATICI

Full range of pneumatic cylinders, with **polyurethane seals and stainless steel rods**.
All the ISO standard families are available, with big-size cylinders up to $\varnothing 320$.
All cylinders can be supplied with seals for **very low and very high temperatures**.

*Gamma completa di cilindri pneumatici, con **guarnizioni in poliuretano e steli Inox**.
Tutte le **famiglie standard ISO** sono disponibili, con dimensioni fino a $\varnothing 320$).
Tutti i cilindri possono essere forniti con guarnizioni per **basse e alte temperature**.*



VALVES AND SOLENOID VALVES VALVOLE ED ELETTROVALVOLE

Mechanical and solenoid valves with lip seals, **resistant to humidity and dust**.
Solenoid valves can be supplied with H class coils and **with 110V DC coils**.
Vesta valves can be ordered in **low temperature version (-40°C)**.

*Valvole con guarnizioni a labbro per **ambienti umidi e polverosi**.
Elettrovalvole fornibili con bobine speciali Classe H, e **bobine 110V DC**.
Tutte le valvole possono essere ordinate per **bassa temperatura (-40°C)**.*

AIR TREATMENT UNITS GRUPPI DI TRATTAMENTO ARIA

A complete series of regulators and FRL units, **from size G1/4" to G2"**.
All the sizes can be supplied with **metal bowl** for outdoor applications.
Air treatment units can also be provided for **high and low temperatures**.

*Una serie completa di regolatori e unità FRL, **da taglia G1/4" a G2"**.
Tutte le taglie sono disponibili con **tazze in metallo** per utilizzo outdoor.
I gruppi di trattamento aria sono anche per **alte e basse temperature**.*

 Seals for high & low temperature available





Vesta Automation is specialized in making components for industrial automation. Founded in 1984, in **over 40 years of experience** Vesta developed projects in over 60 international markets, specializing in pneumatic automation for outdoor environments and heavy-duty applications: **cement plants, truck equipment, railways and amusement sectors, process.** Production, in the ISO:9001/2015 certified Rovigo plant, ranges from pneumatic cylinders, electric actuators, pneumatic valves and solenoid valves, air treatment units and precision pressure control systems.



Different product certifications can be provided by Vesta.
 Vesta può rilasciare diverse certificazioni di prodotto.

Vesta Automation è un'azienda specializzata nella produzione di componenti per l'automazione industriale. Nata nel 1984, in **oltre 40 anni di esperienza** ha sviluppato progetti nei settori più disparati e in oltre 60 mercati internazionali, specializzandosi nell'automazione pneumatica in ambienti outdoor e applicazioni gravose: **cementifici, attrezzature per camion, componenti per il settore ferroviario e dell'amusement, processo.** La produzione, nello stabilimento di Rovigo certificato ISO:9001/2015, spazia da cilindri pneumatici, attuatori elettrici, valvole ed elettrovalvole pneumatiche, unità di trattamento aria e controllo di precisione della pressione.



Check out Vesta
 Production Range:
 Scopri il Production
 Range di Vesta:



Vesta Automation HQ is located in Rovigo - Italy
 Easily accessible from Venice, Bologna and Milan





PNEUMATIC SYSTEMS FOR STREET CLEANING TRUCKS

SISTEMI PNEUMATICI PER CAMION PULIZIA STRADA

Pneumatic cylinders and solenoid valves mounted on street cleaning trucks must resist to very harsh conditions of operation. **Special sealing systems and hard surface treatments** are needed in order to grant long lasting life and precision in movements, in allweather conditions. **Space saving and easy mounting** are also crucial in this field.

*Cilindri e valvole montate sui camion per la pulizia delle strade devono resistere a condizioni di funzionamento molto difficili. **Guarnizioni e trattamenti speciali** garantiscono lunga durata e precisione nei movimenti, in tutte le condizioni atmosferiche. **Ottimizzazione degli spazi e facilità di montaggio** sono fondamentali in questo campo.*

APPLICATION EXAMPLE:

Movements on street cleaning trucks

SPECIAL REQUEST:

Cylinders with custom fixing dimensions and dust protection (mounted under the truck)

TECHNICAL FEATURES:

Ø63 round cylinder with rear supply
Special rod scraper seal for heavy movements
External protection seals for dust and abrasives

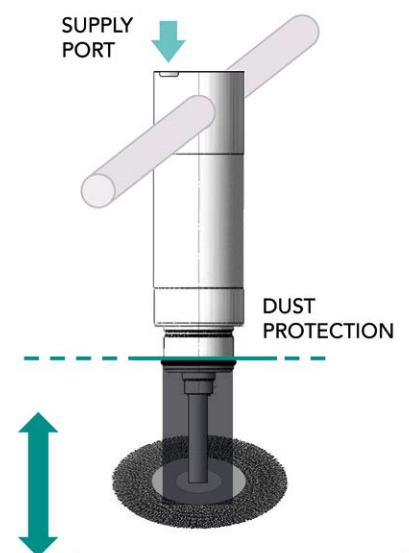
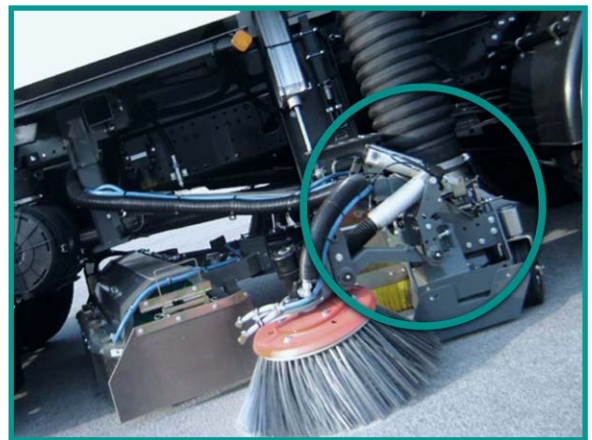



PNEUMATIC SYSTEMS FOR SILO TRUCKS AND FIRE TRUCKS SISTEMI PNEUMATICI PER CAMION SILOS E POMPIERI

With years of experiences in the transportation industry, Vesta provides **full systems** for the control of moving parts in several types of cargo and fire trucks. Cylinders that can resist to all weather conditions, **pneumatic valves with special mechanical/manual functions**, and full-metal air treatment units.

Con anni di esperienza nel settore dei trasporti, Vesta fornisce **sistemi completi** per movimentazioni in diversi ambiti, dai silos ai camion dei pompieri. Cilindri per resistere a tutte le condizioni atmosferiche, **valvole con funzioni meccaniche/manuali speciali**, e unità di trattamento aria completamente in metallo.

APPLICATION EXAMPLE:

Control unit for safety handrail on silo trucks

SPECIAL REQUEST:

Accessible manual control with electrical feedback

TECHNICAL FEATURES:

Manual valves with spool movement detection
Electro-mechanical on/off switch IP67
Cylinders with hard anodization (weather resistance)





VALVES FOR DRAIN TRUCKS AND GARBAGE TRUCKS VALVOLE PER CAMION SPURGHI E SPAZZATURE

Vesta solenoid valves for outdoor applications in humid and dirty environment are equipped with **NBR lip seals and special coils**, with external protection against humidity. Valves and Namur valves are requested to pass a zero-leakage test, in order to grant performance of **dozens of million cycles in extreme conditions**.

Le elettrovalvole Vesta per applicazioni outdoor in ambienti umidi e sporchi sono dotate di **guarnizioni a labbro in NBR e bobine speciali**, con protezione esterna contro l'umidità. Valvole e Namur devono superare un test di tenuta "zero-leakage", al fine di garantire prestazioni di **decine di milioni di cicli anche in condizioni estreme**.

APPLICATION EXAMPLE:

Process control on drain trucks

SPECIAL REQUEST:

High performances in humid outdoor environment

TECHNICAL FEATURES:

Namur valves, 5/2 and 5/3 function
NBR lip seals and high isolation (zero-leak tested)
Coils with special resin coating (humidity protected)

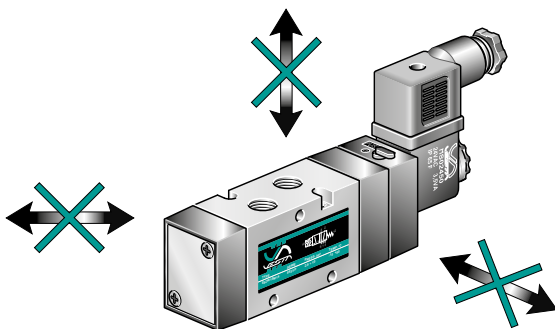
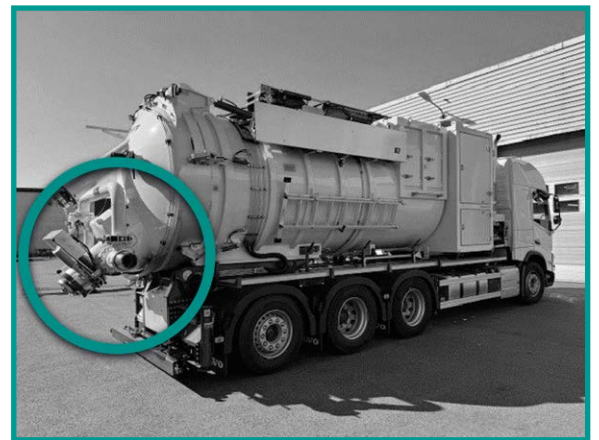



SPECIAL APPLICATIONS ON TRUCKS AND TRACTORS APPLICAZIONI SPECIALI IN CAMION E TRATTORI

APPLICATION EXAMPLE:

Automatic safety winch locking
(mounted on road assistance trucks)

SPECIAL REQUEST:

Strong locking, custom fixing dimensions

TECHNICAL FEATURES:

Single acting Ø25 cylinder
Rear-end supply for rod-in movement
Hardened steel rod end (braking device)

APPLICATION EXAMPLE:

Soil movement in weeding operation
(mounted on tractor tool, 2 Hz cycles)

SPECIAL REQUEST:

Easy to access adjustment, dust protection

TECHNICAL FEATURES:

Ø32 cylinder with stroke adjustment
Rear axial supply, double seal for thin dust
Food-grade grease for agriculture use

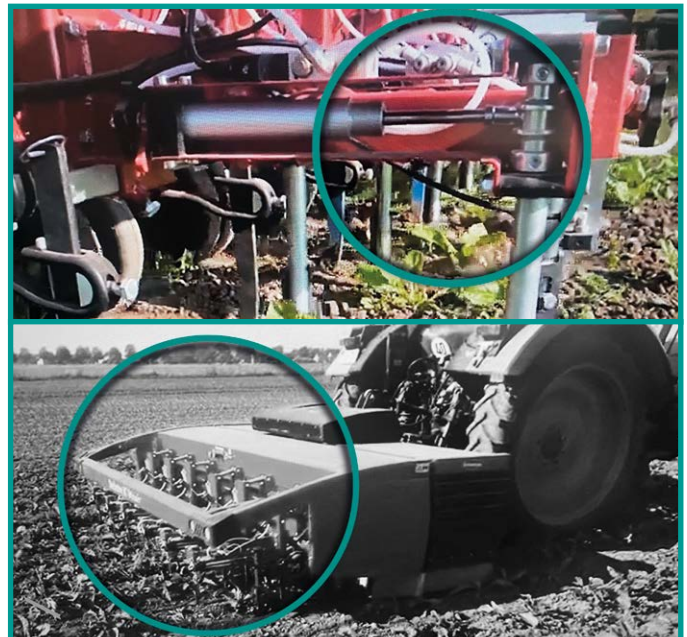
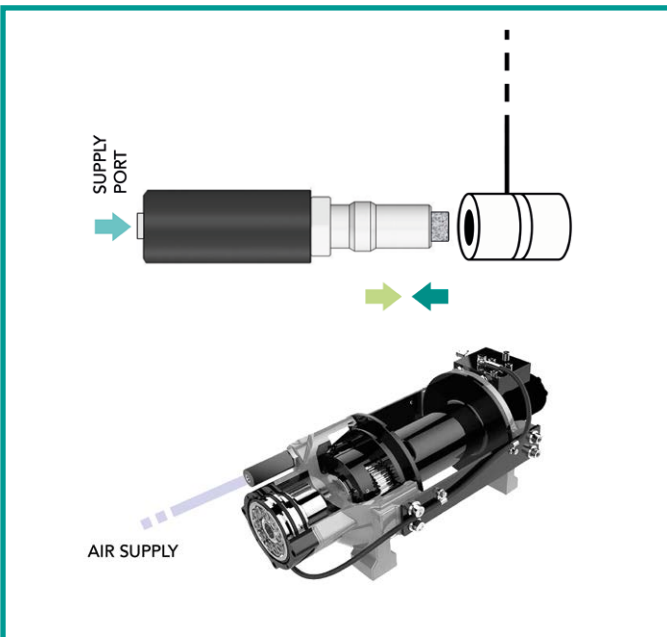



References available upon request. Ask us for more: info@vesta.it
Referenze disponibili su richiesta. Chiedici di più: info@vesta.it





VESTA AUTOMATION srl
Via Martiri di Belfiore 69/A
45100 Rovigo - Italia

 +39 0425 474838
 info@vesta.it
 Vesta Automation Srl

Check out Vesta
Production Range:
*Scopri il Production
Range di Vesta:*

