

**DIGITAL  
PROPORTIONAL VALVE**  
VALVOLA PROPORZIONALE  
A COMANDO ELETTRICO

1/8", 1/4", 1/2" size available  
Disponibile in taglia 1/8", 1/4", 1/2"

**Easy settings &  
integrated LCD display.**  
Facile da programmare,  
display LCD integrato.

# DPV

## Series



**4 input and 4 output  
control signals  
(analog and switch).**  
4 segnali di ingresso e 4  
segnali di controllo  
(analogico e digitale)



**3 regulation ranges,  
from 0,05 to 9 bar**  
3 range di regolazione  
da 0,05 a 9 Bar





## DESCRIPTION / DESCRIZIONE

Vesta DPV series guarantees a stepless control of pressure by proportional electric signals, along with a construction technology based on a pneumatic-pilot high-sensitivity diaphragm. Easy and quick to program, DPV can be controlled with 4 different input signals (current or voltage) and it provides 4 different output signals (analog or switch). Power supply is DC24V. The display can be set in MPA, BAR, PSI pressure units. The series is available in three sizes: 1/8", 1/4" and 1/2", each of them with 3 different options of pressure ranges, from 0.05 to 9 Bar.

Vesta DPV garantisce un controllo continuo e preciso della pressione tramite segnali elettrici proporzionali, uniti ad una tecnologia costruttiva a membrana con pilotaggio pneumatico ad alta sensibilità. La programmazione è semplice ed immediata; può essere comandata con 4 diversi segnali input (in corrente o tensione) e comunicare con 4 diversi segnali output (analogico o digitale/switch). L'alimentazione è DC24V. Il display può essere letto con diverse unità di misura della pressione (MPa, BAR, e PSI). La serie è disponibile in tre diverse taglie: 1/8", 1/4" e 1/2", ognuna con 3 diverse opzioni di range di pressione regolabile, da 0,05 a 9 Bar.

## ENCODING / CODIFICA

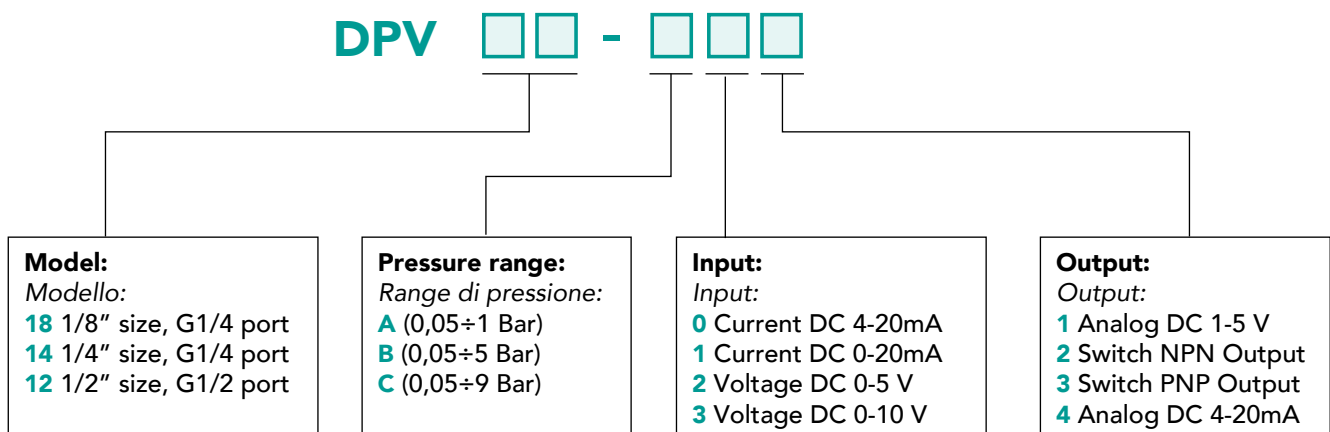

### Cables and brackets / Cavi e staffe di fissaggio (DPV18/14/12)

90° 3mt. cable M12x3 / Cavo 90° 3mt. M12x3	<b>DPV-X</b>
Straight 3mt. cable M12x3 / Cavo dritto 3mt. M12x3	<b>DPV-Y</b>
Flat Bracket / Staffa piatta	<b>DPV-F</b>
L bracket / Staffa a L	<b>DPV-L</b>

**TECHNICAL FEATURES / CARATTERISTICHE TECNICHE**

<b>Pressure range</b> <i>Range disponibili:</i>		A - 0.05 / 1 Bar B - 0.05 / 5 Bar C - 0.05 / 9 Bar
<b>Maximum inlet pressure</b> <i>Pressione massima di ingresso</i>	DPV-A DPV-B/C	2 Bar 10 Bar
<b>Minimum inlet pressure</b> <i>Pressione minima</i>		Set Pressure + 1 Bar
<b>Ambient and fluid temperature</b> <i>Temperatura ambiente e fluido</i>		0-50°C
<b>Protection class</b> <i>Classe di protezione</i>		IP65
<b>Power Supply</b> <i>Alimentazione elettrica</i>		DC 24V±10%
<b>Input Signal</b> <i>Segnale Input</i>	Voltage / Voltaggio Current / Tensione	DC 4~20mA, DC 0~20mA DC 0~5V, DC 0~10V
<b>Input Impedance</b> <i>Impedenza Input</i>	Voltage / Voltaggio Current / Tensione	≤10Ω ~6,5 KΩ
<b>Output Signal</b> <i>Segnale Output</i>	Analog / Analogico Switch / Digitale	DC 1~5V (impedance 1KΩ or more) DC 4~20mA (impedance 250Ω or less) NPN. PNP: 30mA
<b>Linearity</b> <i>Linearità</i>		1% F.S.
<b>Hysteresis</b> <i>Isteresi</i>		0,5% F.S.
<b>Repeatability</b> <i>Ripetibilità</i>		0,5% F.S.
<b>Temperature Drift</b> <i>Variazione di temperatura</i>		2% F.S.
<b>Response time</b> <i>Tempo di risposta</i>	DPV18 DPV14 DPV12	0,2-0,3s 0,2-0,3s 0,3-0,4s
<b>Display</b> <i>Display</i>	Accuracy / Precisione Unit / Unità di misura	2% F.S. M Pa, bar, PSI
<b>Weight</b> <i>Peso</i>	DPV18 DPV14 DPV12	270 gr 385 gr 800 gr

**Note: for optimal use, filtered air (5μ) not lubricated / Nota: per utilizzo ottimale, aria filtrata (5μ) non lubrificata**

## PNEUMATIC FUNCTIONING / FUNZIONAMENTO PNEUMATICO

As the electric input signal increases, the supply and exhaust solenoid valves provide pressure control to the diaphragm that opens the supply valve; this guarantees a precise output of pressure that is constantly controlled by an electronic sensor, and kept regulated proportionally to the input signal. Over pressure (or back pressure) is quickly exhausted by a high-flow exhaust valve. The exhaust of the pilot solenoid valves can be conveyed.

Con l'aumento del segnale elettrico di input, le elettrovalvole di carico e scarico comandano pressione sulla membrana che controlla l'apertura della valvola di alimentazione; questo permette di un preciso output di pressione in uscita, che viene costantemente monitorata da un sensore elettronico, e tenuta regolata proporzionalmente al segnale di input. La sovrappressione (o contropressione) viene velocemente scaricata da una valvola di scarico ad alta portata. Lo scarico delle elettrovalvole di pilotaggio può essere convogliato.

## DPV18

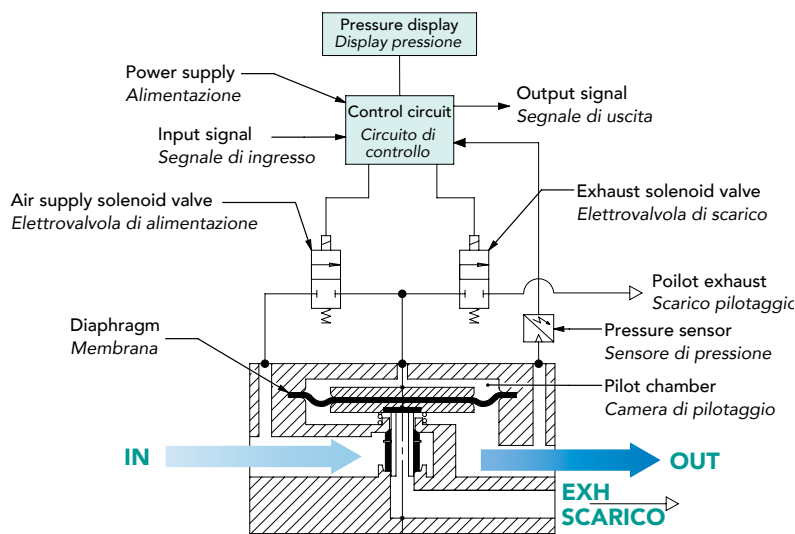

## DPV14-12

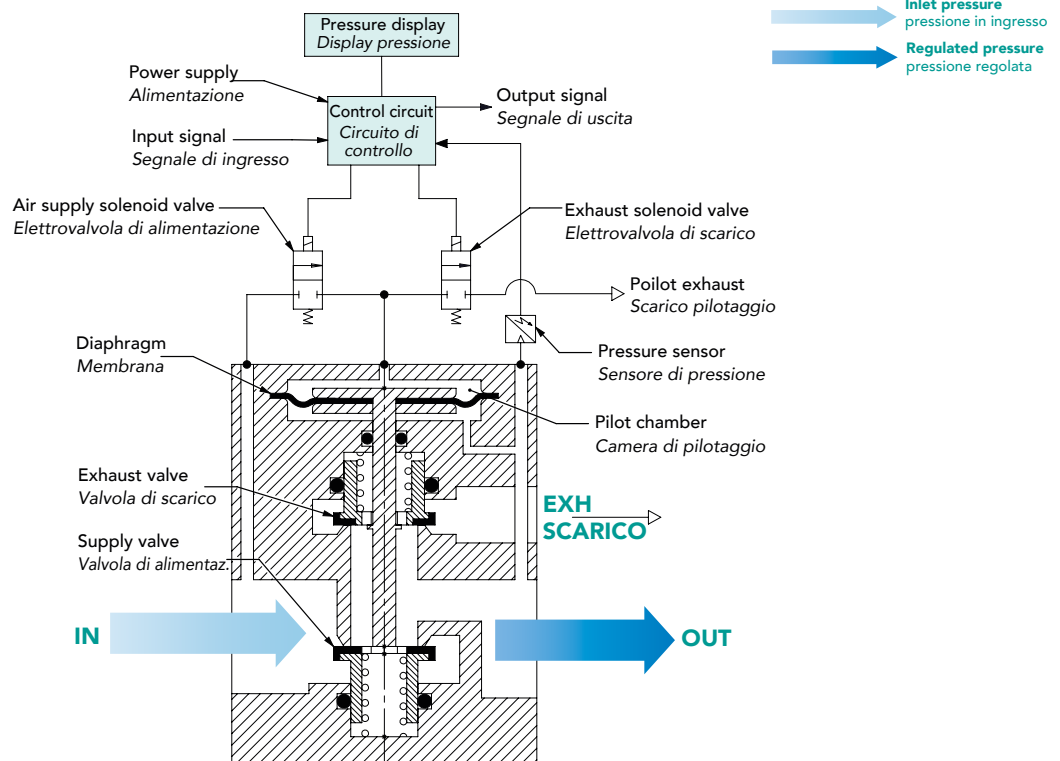

FLOW RATE DPV18 / PORTATA DPV18

A (0.05÷1 Bar)

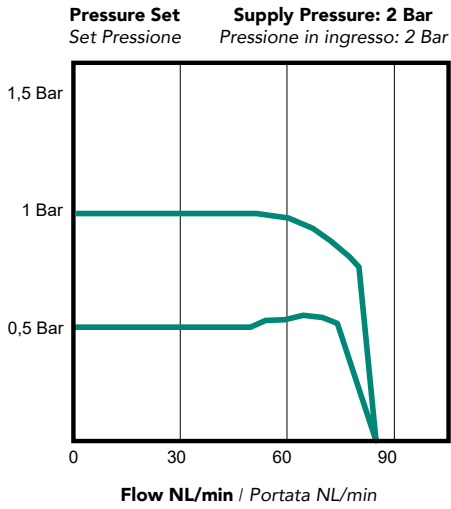

B (0.05÷5 Bar)

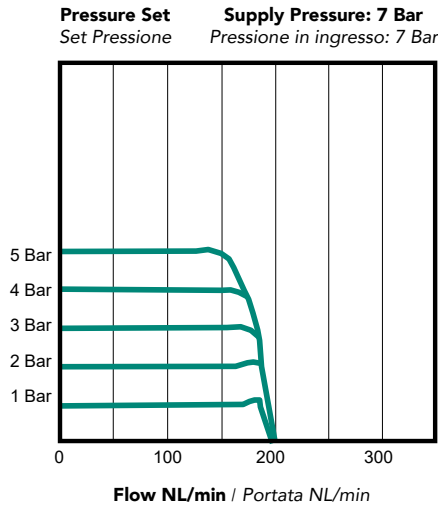

C (0.05÷9 Bar)

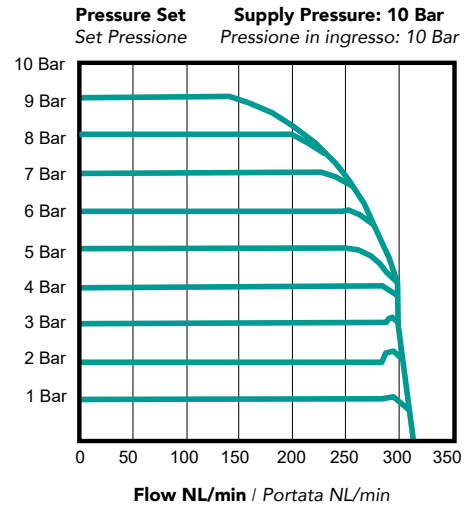

FLOW RATE DPV14 / PORTATA DPV14

A (0.05÷1 Bar)

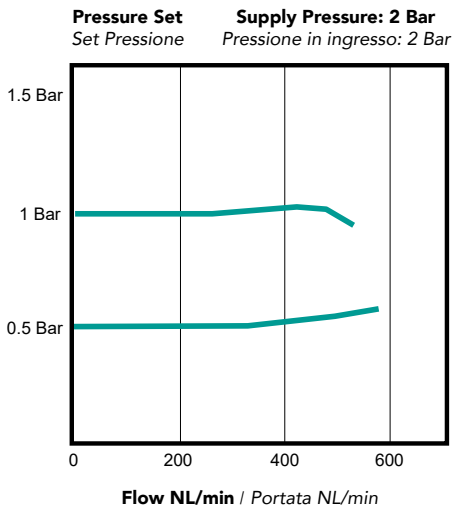

B (0.05÷5 Bar)

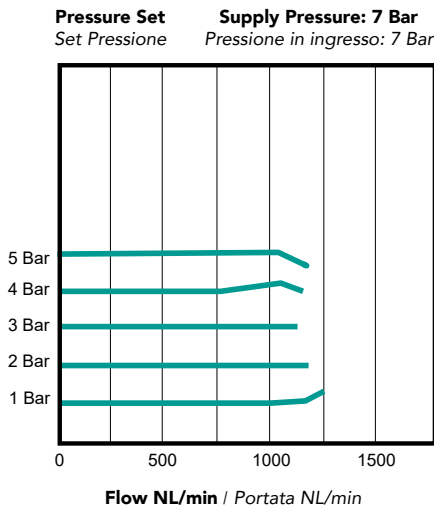

C (0.05÷9 Bar)

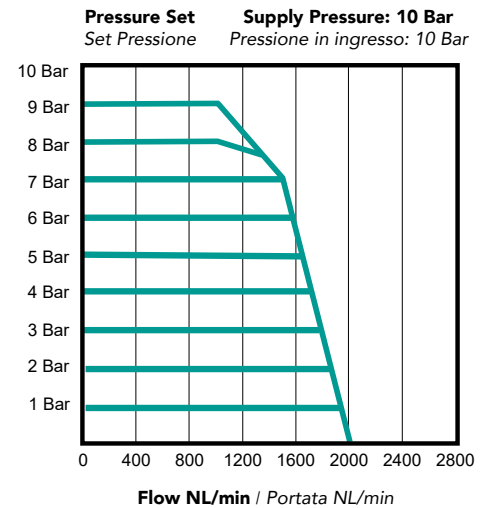

FLOW RATE DPV12 / PORTATA DPV12

A (0.05÷1 Bar)

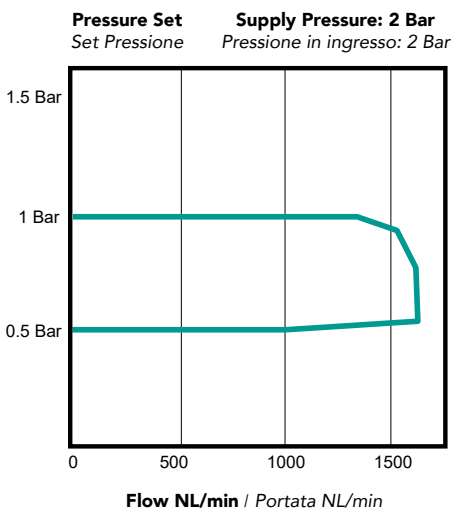

B (0.05÷5 Bar)

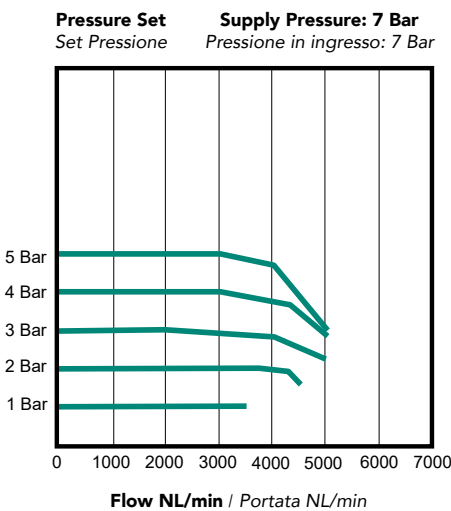

C (0.05÷9 Bar)

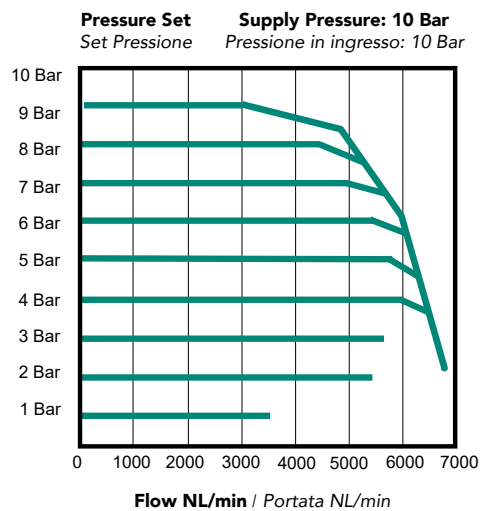

RELIEF CHARACTERISTICS DPV18 / SCARICO PRESSIONE DPV18

A (0.05÷1 Bar)

Pressure set / Set pressione  
Back pressure 2 Bar / Contropressione 2 Bar

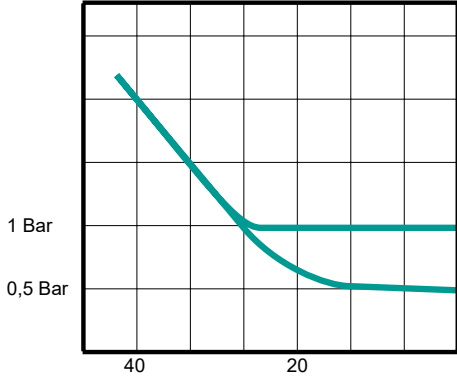

Flow NL/min / Portata NL/min

B (0.05÷5 Bar)

Pressure set / Set pressione  
Back pressure 7 Bar / Contropressione 7 Bar

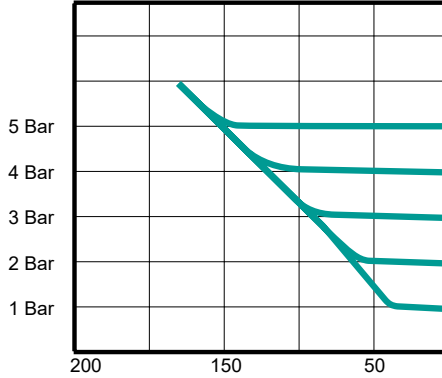

Flow NL/min / Portata NL/min

C (0.05÷9 Bar)

Pressure set / Set pressione  
Back pressure 10 Bar / Contropressione 10 Bar

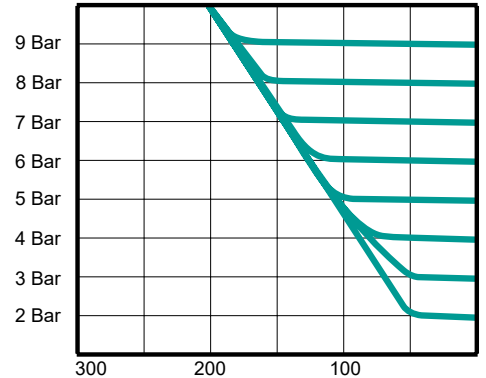

Flow NL/min / Portata NL/min

RELIEF CHARACTERISTICS DPV14 / SCARICO PRESSIONE DPV14

A (0.05÷1 Bar)

Pressure set / Set pressione  
Back pressure 2 Bar / Contropressione 2 Bar

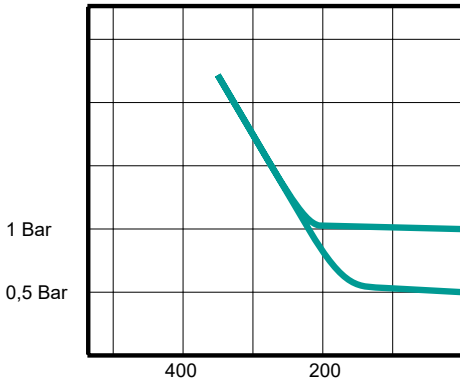

Flow NL/min / Portata NL/min

B (0.05÷5 Bar)

Pressure set / Set pressione  
Back pressure 7 Bar / Contropressione 7 Bar

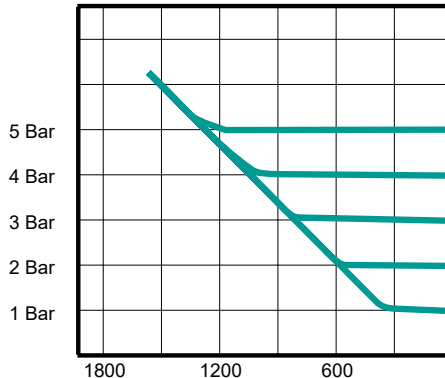

Flow NL/min / Portata NL/min

C (0.05÷9 Bar)

Pressure set / Set pressione  
Back pressure 10 Bar / Contropressione 10 Bar

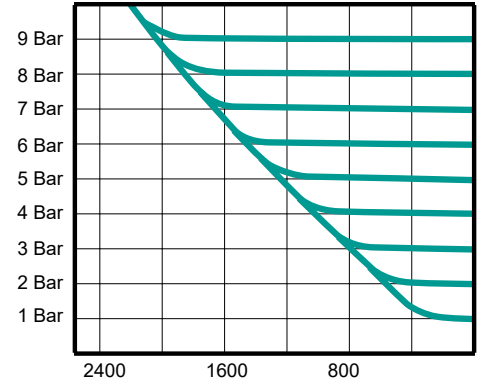

Flow NL/min / Portata NL/min

RELIEF CHARACTERISTICS DPV12 / SCARICO PRESSIONE DPV12

A (0.05÷1 Bar)

Pressure set / Set pressione  
Back pressure 2 Bar / Contropressione 2 Bar

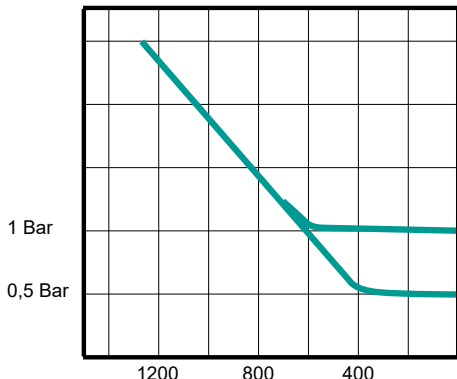

Flow NL/min / Portata NL/min

B (0.05÷5 Bar)

Pressure set / Set pressione  
Back pressure 7 Bar / Contropressione 7 Bar

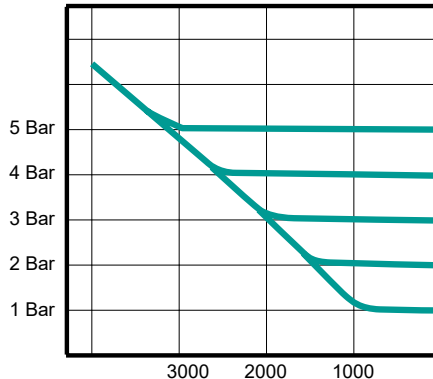

Flow NL/min / Portata NL/min

C (0.05÷9 Bar)

Pressure set / Set pressione  
Back pressure 10 Bar / Contropressione 10 Bar

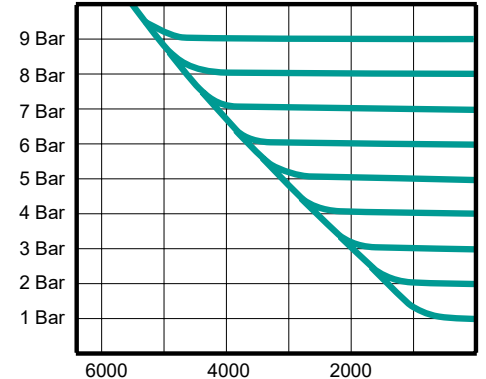

Flow NL/min / Portata NL/min



**DPV18**

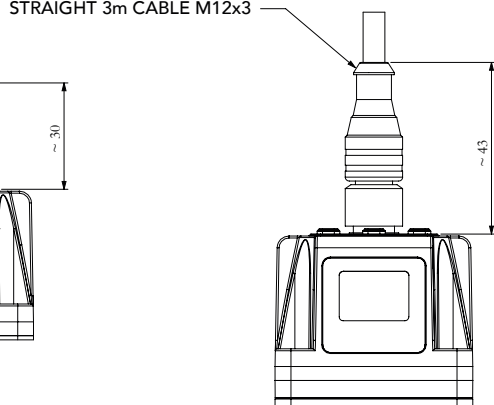
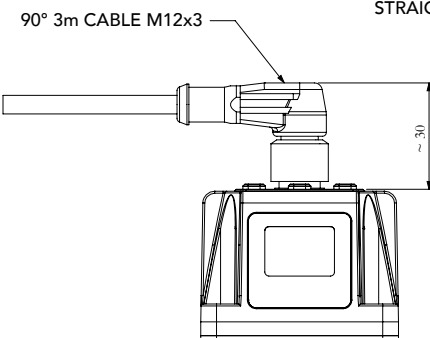
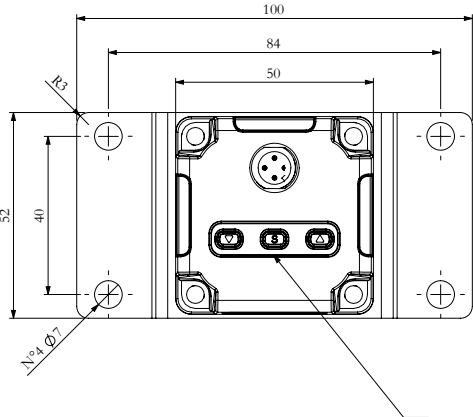

Keys for Unit setting, Display settings, Manual pressure settings, Error settings.  
All information about Setting Method is available in the DPV Operation Manual.

*Pulsanti per Unit setting, Display settings, Manual pressure settings, Error settings.  
Tutte le informazioni sono disponibili nel Manuale Operativo.*

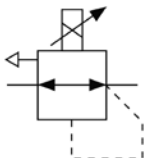

**FLAT BRACKET ASSEMBLY**  
**STAFFA PIATTA**

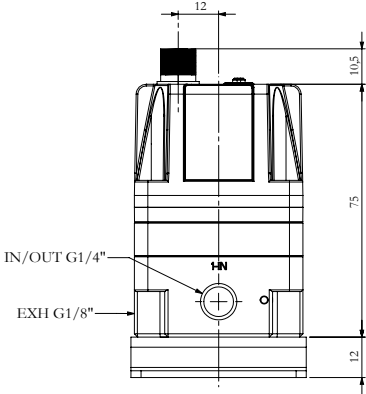
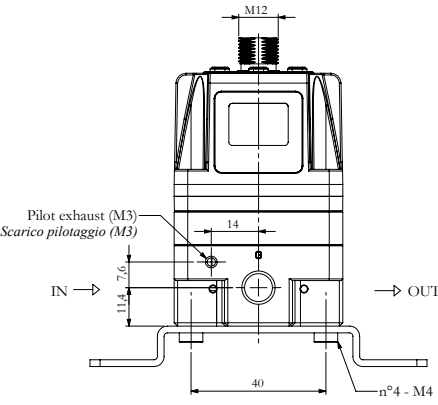

**L BRACKET ASSEMBLY**  
**STAFFA A L**

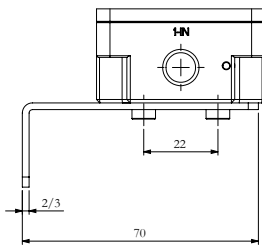
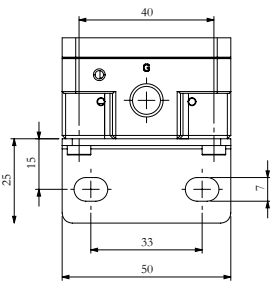

**DPV14**

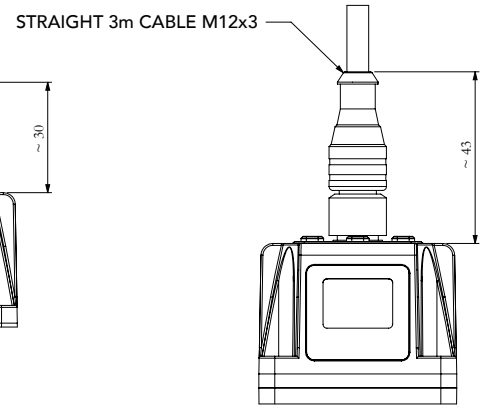
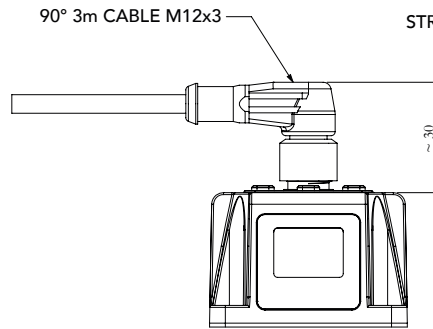
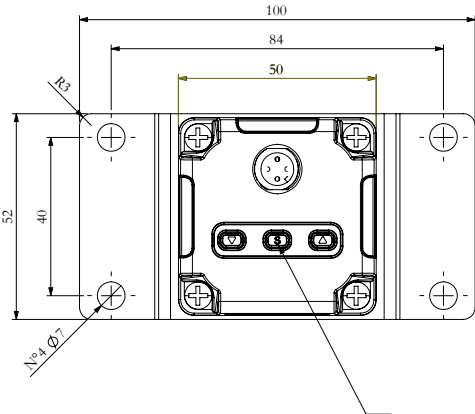

Keys for Unit setting, Display settings, Manual pressure settings, Error settings.  
All information about Setting Method is available in the DPV Operation Manual.

*Pulsanti per Unit setting, Display settings, Manual pressure settings, Error settings.  
Tutte le informazioni sono disponibili nel Manuale Operativo.*

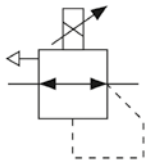

**FLAT BRACKET ASSEMBLY**  
STAFFA PIATTA

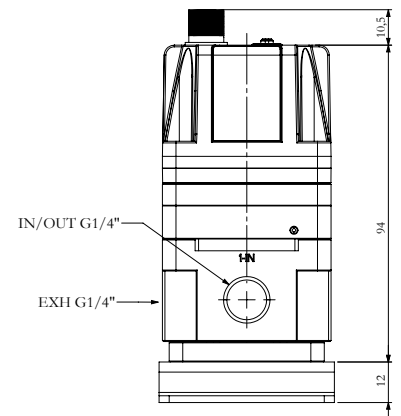
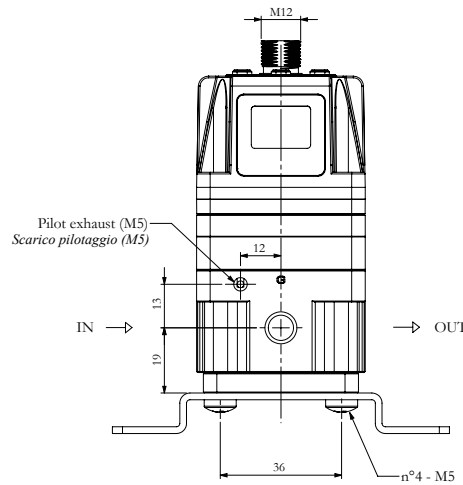

**L BRACKET ASSEMBLY**  
STAFFA A L

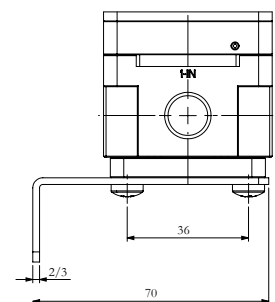
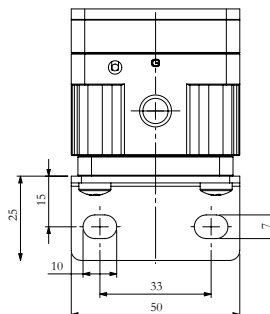



**DPV12**

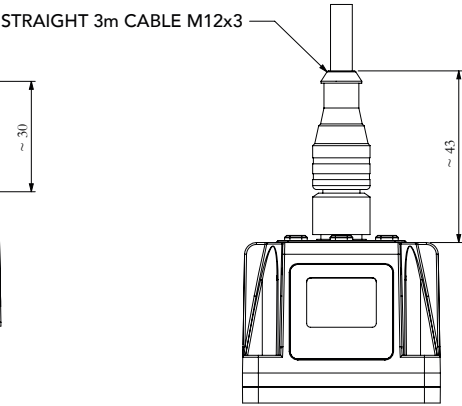
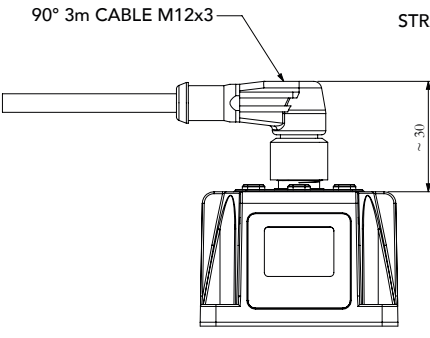
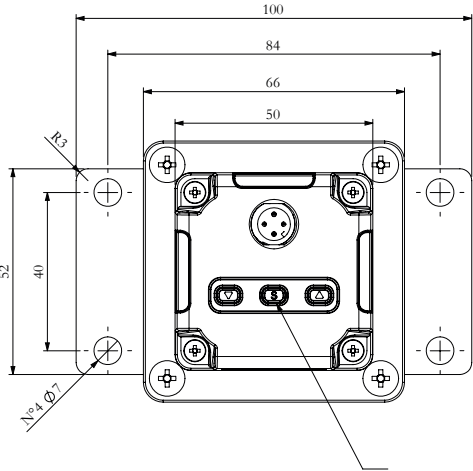

Keys for Unit setting, Display settings, Manual pressure settings, Error settings.  
All information about Setting Method is available in the DPV Operation Manual.  
*Pulsanti per Unit setting, Display settings, Manual pressure settings, Error settings.*  
*Tutte le informazioni sono disponibili nel Manuale Operativo.*

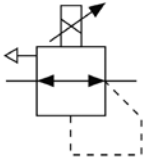

**FLAT BRACKET ASSEMBLY**  
**STAFFA PIATTA**

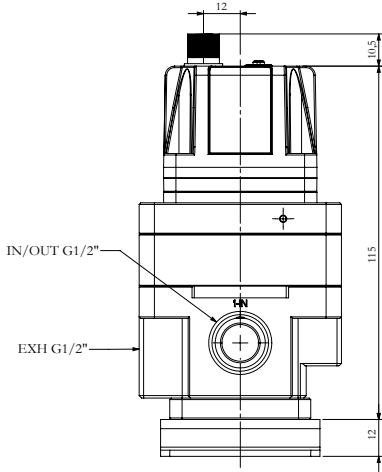
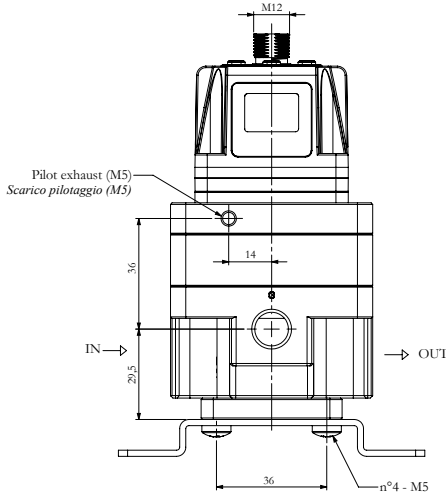

**L BRACKET ASSEMBLY**  
**STAFFA A L**

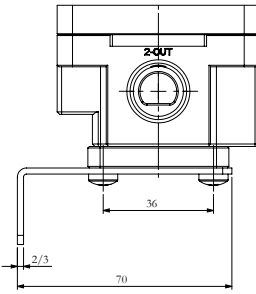
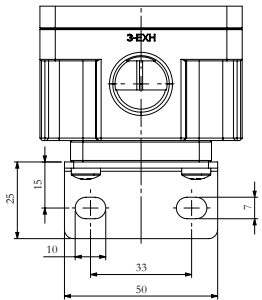

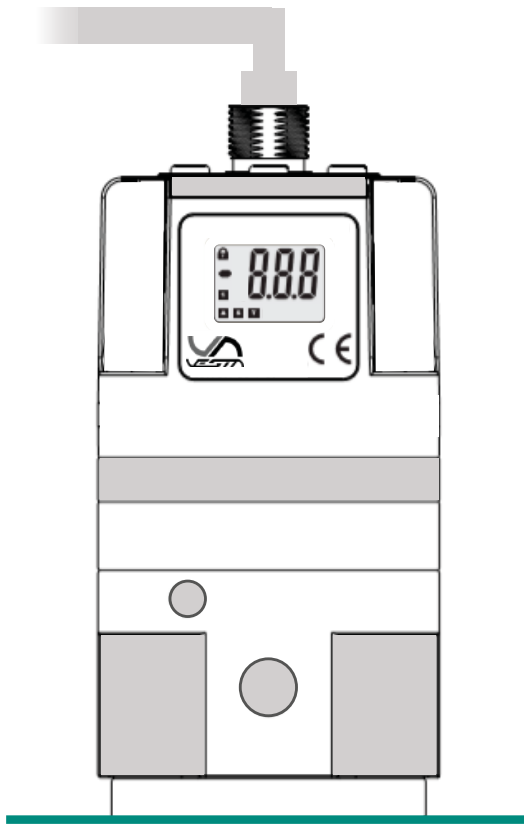

## SIGNAL & DISPLAY / SEGNALE E DISPLAY

DPV valve is controlled by a 14 bit internal analog-to-digital converter capable of analyzing high resolution input signals (Current: 4-20mA, 0-20mA or Voltage: 0-5V, 0-10V).

The high-brightness LCD display can be set in different units (BAR, MPA, PSI) and allows different settings, such as the scaling of input signal, manual pressure regulation, programmable pressure ranges and different levels of response/sensitivity. Safety features include the manumission-protection locking of the keyboard, and the pressure retainment of the last input if power supply is cut off.

More information available in the Operation Manual.

*La valvola DPV è controllata da un convertitore analogico-digitale interno a 14 bit, in grado di apprezzare valori di segnale input ad elevata risoluzione, in corrente (4-20mA, 0-20mA) o tensione (0-5V, 0-10V).*

*Il display ad alta luminosità riproduce diverse unità di misura (BAR, MPA, PSI) e permette di accedere a diversi tipi di setting, come la gestione del segnale di ingresso, la regolazione manuale della pressione, la programmazione di range di pressione e la gestione della risposta/sensibilità della valvola.*

*Ulteriori caratteristiche sono il bloccaggio antimissione della tastiera, e la tenuta della pressione dell'ultimo segnale in caso di perdita di corrente.*

*Maggiori informazioni sono disponibili nel manuale operativo.*

## OPERATION MANUAL / MANUALE OPERATIVO

The following instructions are available in the Operation Manual:

*Le seguenti istruzioni sono disponibili nel manuale operativo*

- **Wiring & Connections**
- *Cablaggio e connessioni elettriche*
- **Setting Method: manual setting of minimum and maximum pressure (P1-P2)**
- *Settaggio manuale della pressione minima e pressione massima (P1-P2)*
- **Switch Output mode (Window Comparator, Hysteresis, Out Of Range)**
- *Modalità di output switch (Window Comparator, Hysteresis, Out Of Range)*
- **Function settings (F01 Unit, F02 Input Adjustment, F03 Gain Level, F04 Zero Clear, F05 Initialize)**
- *Regolazione funzioni (F01 unità di misura, F02 segnale input, F03 sensibilità, F04 Zero Clear, F05 reset)*
- **Preset pressure setting**
- *Preset dei valori di pressione*
- **Error messages & Actions**
- *Messaggi di errore e azioni di ripristino*

## INPUT SIGNAL LINEARITY / LINEARITÀ DEL SEGNALE INPUT

C (0.05÷9 Bar)

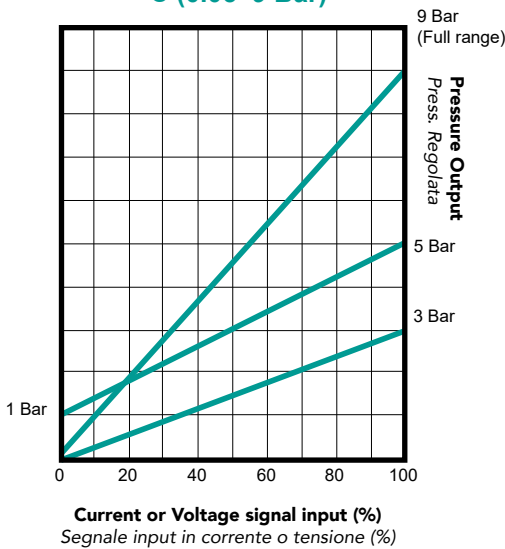

DPV allows to set different ranges of pressure, always using 100% of the input signal (Current or Voltage).

This chart shows the linearity of different examples of applications with a regulation range from 0 to 9 Bar.

The input signal can control the full pressure range (from 0 to 9 Bar), or different levels of maximum and minimum pressure (P1 and P2), which can be manually reduced from the top and/or the bottom of the available pressure range (shown examples are from 0 to 3 Bar and from 1 to 5 Bar).

*La valvola DPV permette di settare diversi range di pressione, utilizzando sempre il 100% del segnale input (in corrente o tensione).*

*Questo grafico mostra la linearità di diverse applicazioni esemplificative con un range di regolazione da 0 a 9 Bar.*

*Il segnale input può controllare l'intero range di pressione (da 0 a 9 Bar), o diversi livelli di pressione minima e massima (P1 e P2), che possono essere ridotti manualmente dall'altro e/o dal basso del range di pressione disponibile (gli esempi mostrati sono da 0 a 3 Bar e da 1 a 5 Bar).*

## OUTPUT SIGNAL / SEGNALE OUTPUT

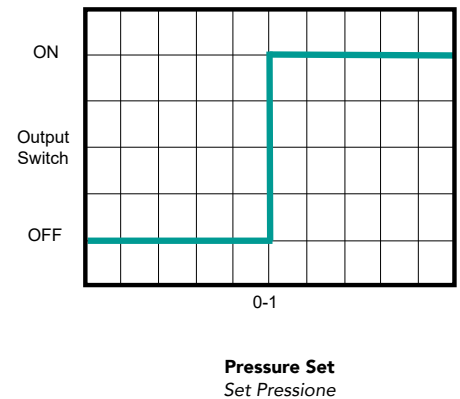
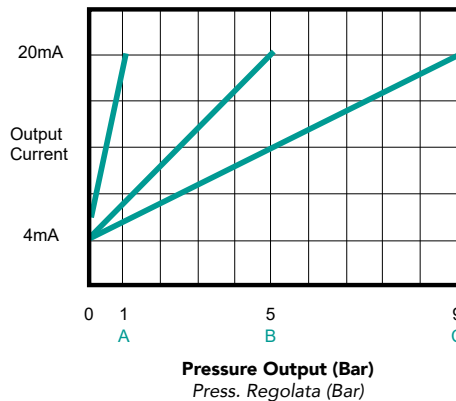
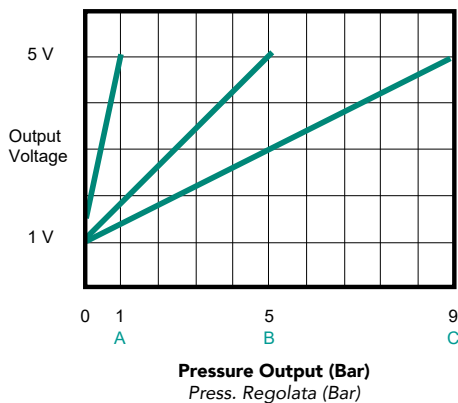

Operating pressure value output is available with analog signal (Current 4-20mA or Voltage 1-5V) or with switch ON-OFF signal (PNP, NPN) that can be read in three modes: Window Comparator, Hysteresis, Out of Range. More information available in the Operation Manual.

*L'output per la rilettura del valore di pressione è disponibile con segnali analogici (in corrente 4-20mA o tensione 1-5V) o con segnale digitale switch ON-OFF (PNP, NPN) che possono essere letti in tre modalità: Window Comparator, Hysteresis, Out of Range. Maggiori informazioni sono disponibili nel manuale operativo.*

## FIELDS OF APPLICATION / SETTORI DI APPLICAZIONE

Vesta DPV proportional valves series can be applied in different industrial fields, for a number of precision control applications. Different sizes offer different flow rates, making DPV suitable for a wide range of automation needs:

La serie di valvole proporzionali Vesta DPV può essere usata in diversi ambiti industriali, per un ampio numero di applicazioni dove è richiesto controllo di precisione. Le diverse taglie offrono diverse portate, rendendo la valvola DPV adatta a rispondere a svariate esigenze di automazione:

- **Plastic moulding , for securing application and control in extrusion**  
*Stampa plastica, per il controllo preciso e dinamico dell'estrusione*
- **Winding and laminating , for friction roller precision deceleration and contact systems**  
*Avvolgimento e laminazione, sistemi a contatto e decelerazione di precisione*
- **Printing and packaging, for controlling contact winding rollers for precise paper tension**  
*Stampa e packaging, per tensionamento preciso e controllato della carta*
- **Lifting and handling , for precise manipulation and gripping, zero gravity load manipulators**  
*Manipolazione e sollevamenti, per il controllo di azzeratori di gravità*
- **Welding, for maximum control in welding guns approaching and precision holding**  
*Saldatura, per il massimo controllo nel posizionamento delle pistole di saldatura*
- **Lapping and polishing , for precision holding in special fields ( glass and marble surfaces)**  
*Smerigliatura e lucidatura, per sistemi di blocco in settori speciali ( vetro e marmo)*
- **Pneumatic system testing, for checking pressure ramps , leak proof , dynamic response**  
*Test di sistemi pneumatici, per il controllo di rampe di pressione e perdite*
- **Fluid process, for precisely adjusting the pressure output of pumps and blowing applications**  
*Processo per regolazione precisa dell'output di pompe e sistemi di soffio*

## FRL GROUP ASSEMBLY / ASSEMBLAGGIO IN GRUPPO FRL

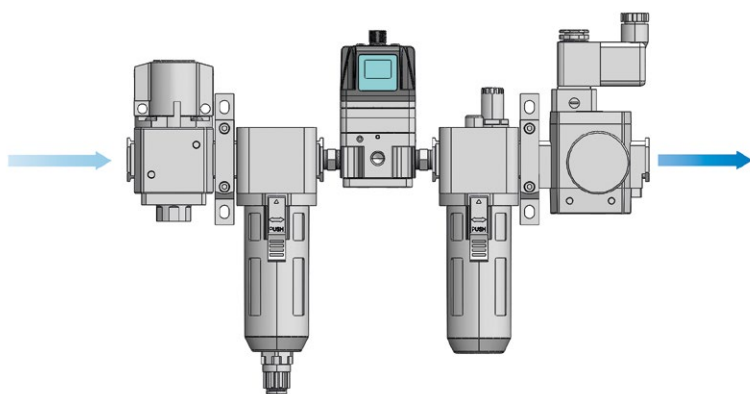

The proportional valve can be mounted within a FRL/air treatment group, after the filtering element (5 $\mu$  filtering element for optimal use) and before the lubricator.

La valvola proporzionale può essere montata all'interno del gruppo FRL/unità di trattamento dell'aria, collocata a valle del filtro (per un utilizzo ottimale si consiglia un elemento filtrante da 5 $\mu$ ) e prima del lubrificatore.

